

FEB156-001 User's Guide
Motor Control Evaluation Board Using the
Motion-SPM™ (FSAM20SM60A) in a DIP
(60mm x 31mm) Package



Contents

1. Introduction.....	3
1.1 Product Description	3
1.2 Circuit Description.....	3
2. Designed Solution.....	4
2.1 Schematic	4
2.2 Bill of Materials	5
2.3 Printed Circuit Board	6
3.0 Selection of the Recommended R _{SC} Resistor.....	10

1. Introduction

This user's guide supports the FSAM20SM60A, Motion-SPM™ in a DIP package evaluation board. It should be used in conjunction with the FSAM20SM60A data sheet.

1.1 Product Description

The Motion-SPMs in DIP packages provide complete adjustable-speed motor drive control and fully-integrated circuit protection for ac motors found in medium-speed low-power inverter driven applications such as washing machines and air conditioners. Fairchild's FSAM20SM60A combines optimized circuit protection and drive matched to low-loss IGBTs. Highly effective short-circuit current detection/protection is realized through the use of advanced current sensing IGBT chips that allow continuous monitoring of the IGBTs current. System reliability is further enhanced by the built-in over-temperature monitoring and integrated undervoltage lock-out protection. The high speed built-in HVIC provides opto-coupler-less IGBT gate driving capability that further reduce the overall size of the inverter system design. In addition the incorporated HVIC facilitates the use of single-supply drive topology enabling the FSAM20SM60A to be driven by only one drive supply voltage without negative bias. Inverter current sensing application can be achieved due to the divided negative dc terminals. This Motion-SPM is available in a small (60mm x 31mm), ceramic-based transfer molded-type package that optimizes heat transfer from the IGBTs.

1.2 Circuit Description

The Motion-SPM is installed as the switching module in this evaluation board with direct CPU interface and without a shunt resistor. This board internally consists of Motion-SPM, protection parts including UV and short-current(SC) protection, single grounded power supply and opto-coupler-less interface, bootstrap components, temperature sensing part for internal thermistor, fault output part and power connection terminals (DC-link input(P,N) as well as a motor input connection(U,V,W)). The DC-link(P and N) input terminals are connected into the corresponding terminals in Motion-SPM and three-phase (U,V,W) output terminals from SPM are wired into motor input. Since the three HVICs are integrated in the Motion-SPM, 3 parts of bootstrap circuit are needed, which consists of bootstrap capacitor, charge resistor for charging boost capacitor, blocking diode for high voltage isolation. One shunt resistor is used for sensing short current and the related short current circuit is composed of an external shunt resistor and R-C low pass filter. The signal of fault output pin VFO drops from high level to low when a fault, such as UV (Under Voltage) or SC (Short Circuit), happens. A pull-up resistor and filter capacitor are needed to support this action. Six R-C low pass filters are used between input connector from a DSP controller (or other controllers) and gate input signal pins of Motion-SPM. Since the thermistor is integrated in the SPM, an external resistor and filter capacitor are used for over-temperature monitoring.

2. Designed Solution

2.1 Schematic

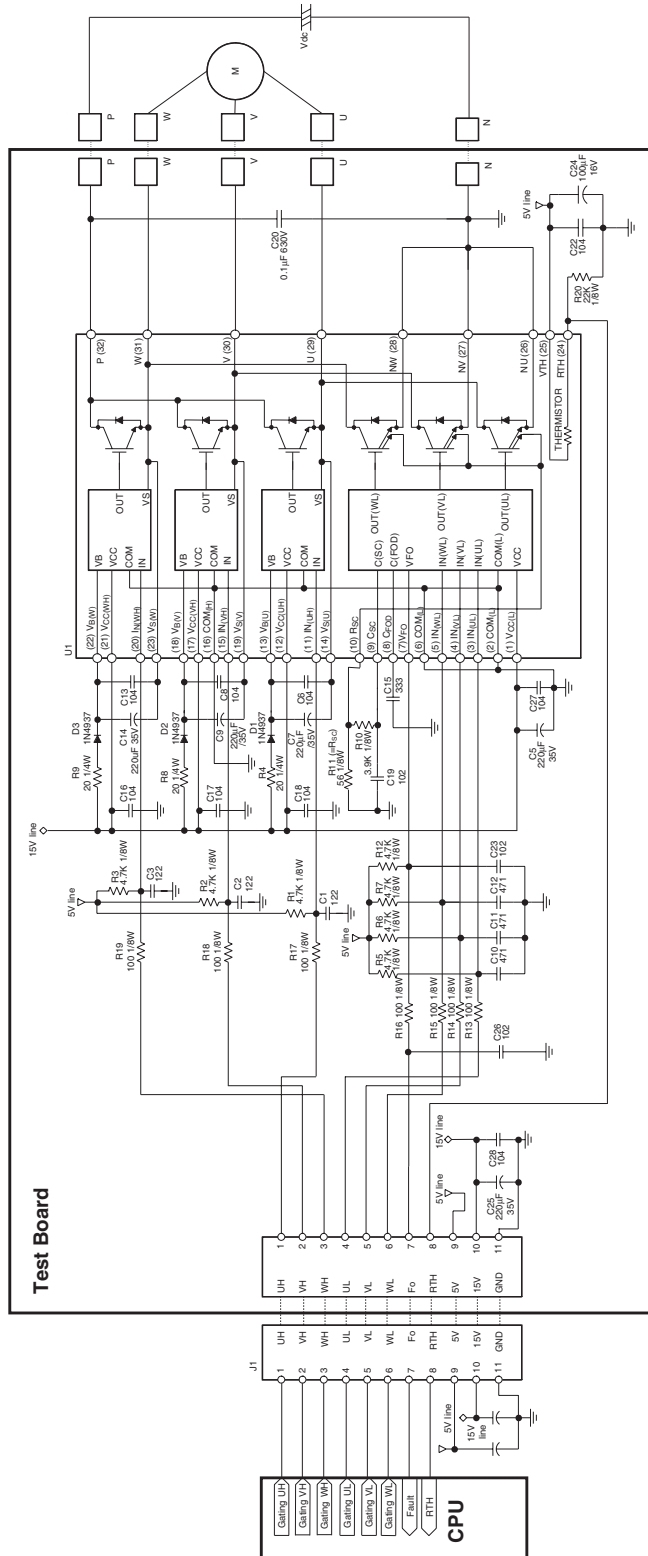

Notes:

1. Common-grounded power supplies of +5V and +15V are used for CPU and SPM2 operation.
2. For further details, see the datasheet and application note.

2.2 Bill of Materials

Part No.	Rating	Characteristics	Definition
R1	4.7k Ω , 1/8W	Carbon Film Resistor (5%)	Pull-Up Resistor (UH)
R2	4.7k Ω , 1/8W	Carbon Film Resistor (5%)	Pull-Up Resistor (VH)
R3	4.7k Ω , 1/8W	Carbon Film Resistor (5%)	Pull-Up Resistor (WH)
R4	20 Ω , 1/4W	Carbon Film Resistor (5%)	Bootstrap Resistor (Phase U)
R5	4.7k Ω , 1/8W	Carbon Film Resistor (5%)	Pull-Up Resistor (UL)
R6	4.7k Ω , 1/8W	Carbon Film Resistor (5%)	Pull-Up Resistor (VL)
R7	4.7k Ω , 1/8W	Carbon Film Resistor (5%)	Pull-Up Resistor (WL)
R8	20 Ω , 1/4W	Carbon Film Resistor (5%)	Bootstrap Resistor (Phase V)
R9	20 Ω , 1/4W	Carbon Film Resistor (5%)	Bootstrap Resistor (Phase W)
R10	3.9k Ω , 1/8W	Carbon Film Resistor (5%)	Low-Pass-Filter for Current Sensing
R11 (=R _{sc})	56 Ω , 1/8W	Carbon Film Resistor (5%)	Current Sensing Resistor
R12	4.7k Ω , 1/8W	Carbon Film Resistor (5%)	Pull-Up Resistor (Fault-Out)
R13	100 Ω , 1/8W	Carbon Film Resistor (5%)	Series Resistor for Signal Interface (UL)
R14	100 Ω , 1/8W	Carbon Film Resistor (5%)	Series Resistor for Signal Interface (VL)
R15	100 Ω , 1/8W	Carbon Film Resistor (5%)	Series Resistor for Signal Interface (Ω L)
R16	100 Ω , 1/8W	Carbon Film Resistor (5%)	Series Resistor for Signal Interface (Fault-Out)
R17	100 Ω , 1/8W	Carbon Film Resistor (5%)	Series Resistor for Signal Interface (UH)
R18	100 Ω , 1/8W	Carbon Film Resistor (5%)	Series Resistor for Signal Interface (VH)
R19	100 Ω , 1/8W	Carbon Film Resistor (5%)	Series Resistor for Signal Interface (WH)
R20	22k Ω , 1/8W	Carbon Film Resistor (5%)	Voltage Divide Resistor for Thermistor
R48	390 Ω , 1/8W	Carbon Film Resistor (5%)	Series Resistor for Csc
C1	1.2nF	Ceramic Capacitor	High-Side Pull-Up Capacitor (Phase U)
C2	1.2nF	Ceramic Capacitor	High-Side Pull-Up Capacitor (Phase V)
C3	1.2nF	Ceramic Capacitor	High-Side Pull-Up Capacitor (Phase W)
C5	220 μ F, 35V	Electrolytic Capacitor	+15V Bias Voltage Source Capacitor
C6	100nF	Ceramic Capacitor	Bypass Capacitor for Bootstrap Supply (Phase U)
C7	220 μ F, 35V	Electrolytic Capacitor	Bootstrap Capacitor (Phase U) – for washing machines
C8	100nF	Ceramic Capacitor	Bypass Capacitor for Bootstrap Supply (Phase V)
C9	220 μ F, 35V	Electrolytic Capacitor	Bootstrap Capacitor (Phase V) – for washing machines
C10	470pF	Ceramic Capacitor	Low-Side Pull-Up Capacitor (Phase U)
C11	470pF	Ceramic Capacitor	Low-Side Pull-Up Capacitor (Phase V)
C12	470pF	Ceramic Capacitor	Low-Side Pull-Up Capacitor (Phase W)
C13	100nF	Ceramic Capacitor	Bypass Capacitor for Bootstrap Supply (Phase W)

Part No.	Rating	Characteristics	Definition
C14	220 μ F, 35V	Electrolytic Capacitor	Bootstrap Capacitor (Phase W) – for washing machines
C15	33nF	Ceramic Capacitor	Capacitor for Selection of Fault Out Duration
C16	100nF	Ceramic Capacitor	+15V Bias Voltage Bypass Capacitor (WH)
C17	100nF	Ceramic Capacitor	+15V Bias Voltage Bypass Capacitor (VH)
C18	100nF	Ceramic Capacitor	+15V Bias Voltage Bypass Capacitor (UH)
C19	1nF, 25V	Ceramic Capacitor	Low-Pass-Filter for Current Sensing
C20	0.1 μ F, 630V	Film Capacitor	Snubber Capacitor to Suppress the Spike-Voltage
C22	100nF	Ceramic Capacitor	+5V Bias Voltage Bypass Capacitor
C23	1nF	Ceramic Capacitor	Pull-Up Capacitor of Fault-Out Signal
C24	100 μ F, 16V	Electrolytic Capacitor	+5V Bias Voltage Source Capacitor
C25	220 μ F, 35V	Electrolytic Capacitor	+15V Bias Voltage Source Capacitor
C26	1nF	Ceramic Capacitor	Bypass Capacitor for Fault-Out Signal
C27	100nF	Ceramic Capacitor	+15V Bias Voltage Bypass Capacitor
C28	100nF	Ceramic Capacitor	+15V Bias Voltage Bypass Capacitor
D1	1A, 600V	Fast Recovery Diode, (1N4937)	Bootstrap Diode (Phase U)
D2	1A, 600V	Fast Recovery Diode, (1N4937)	Bootstrap Diode (Phase V)
D3	1A, 600V	Fast Recovery Diode, (1N4937)	Bootstrap Diode (Phase W)
U1	20A, 600V		FSAM20SM60A

2.3 Printed Circuit Board

2.3.1 PCB Map

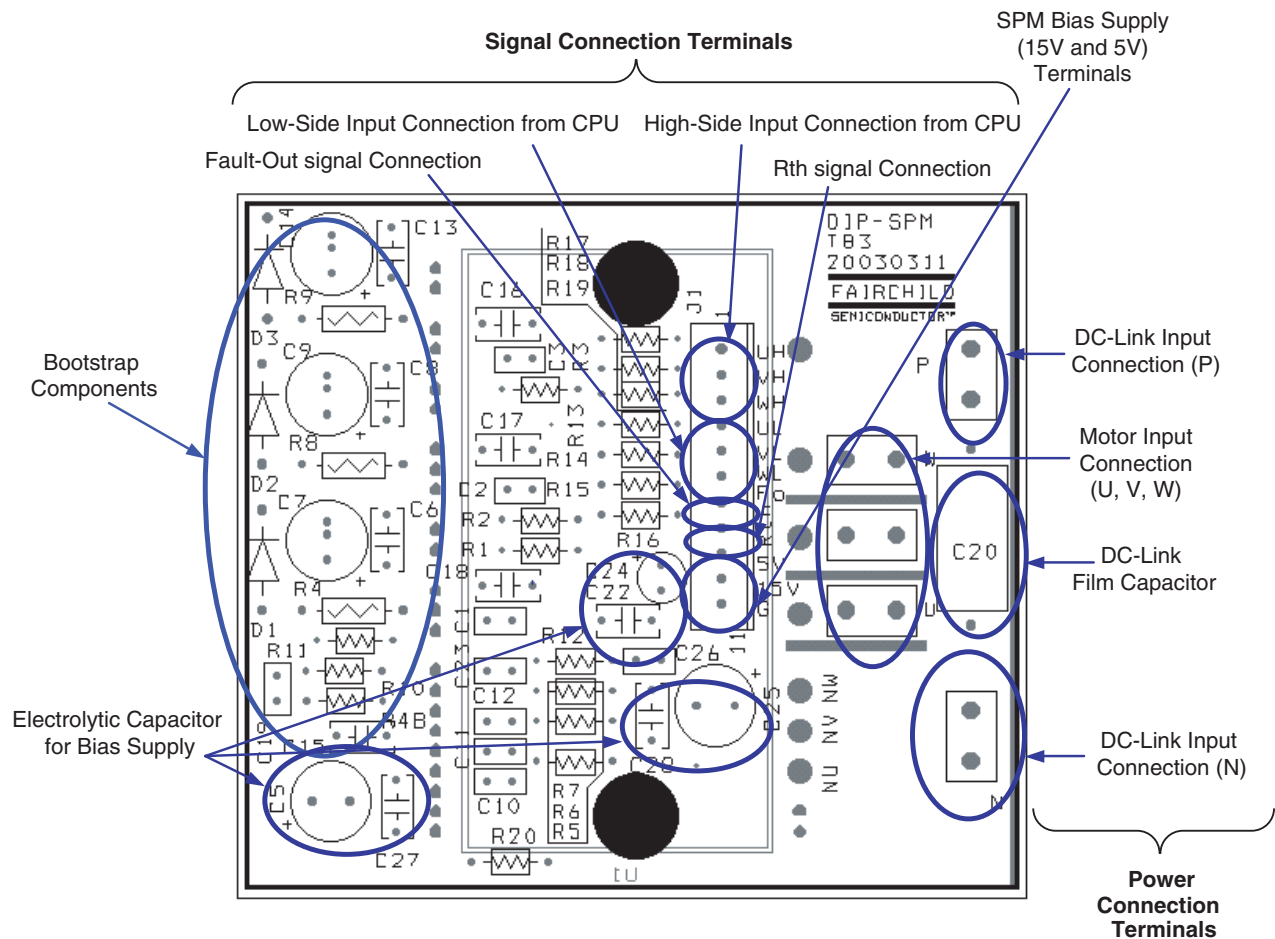

2.3.2 Circuit Layout Design

1. To avoid malfunction, the wiring of each input should be as short as possible. (less than 2-3cm)
2. To prevent protection function errors, the 'Rsc' and 'Csc' wiring should be as short as possible.
3. All the by-pass capacitors and filter capacitors should be placed very close to SPM.
4. The isolation distance of DC-P, U-phase, V-phase, W-phase, DC-N/GND blocks should be over 2.54mm(100mil) for 300V~500V P-N voltage.
5. Power-GND and signal-GND should be connected with each other through only one 1.5~2mm width pattern.
6. To prevent surge destruction, the wiring between the filter capacitor and the P & Ground pins should be as short as possible. The use of a high frequency non-inductive capacitor of around 0.1~0.22 μ F between the P & Ground pins is recommended. In addition to reducing local voltage spikes, the placement and quality of this capacitor will have a direct impact on both conducted and radiated EMI.

2.3.3 External Connection

Signal Interface (J1)	1	High-Side Input Signal from CPU (Phase U)
	2	High-Side Input Signal from CPU (Phase V)
	3	High-Side Input Signal from CPU (Phase W)
	4	Low-Side Input Signal from CPU (Phase U)
	5	Low-Side Input Signal from CPU (Phase V)
	6	Low-Side Input Signal from CPU (Phase W)
	7	Fault-Out Signal to CPU
	8	Thermistor-Out Signal to CPU
	9	SPM Bias Supply +5V Terminal
	10	SPM Bias Supply +15V Terminal
	11	SPM Bias Supply Ground Terminal
Power Connection	P	Positive DC Link Input Connection
	N	Negative DC Link Input Connection
	U	Motor Input Connection (Phase U)
	V	Motor Input Connection (Phase V)
	W	Motor Input Connection (Phase W)

2.3.4 Wiring of PCB

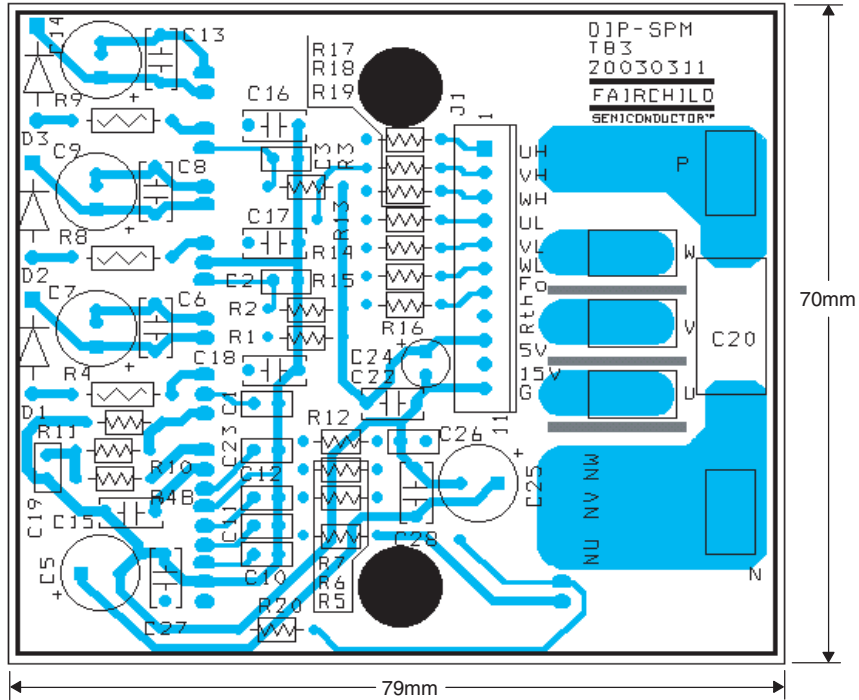

(a) Top Side View

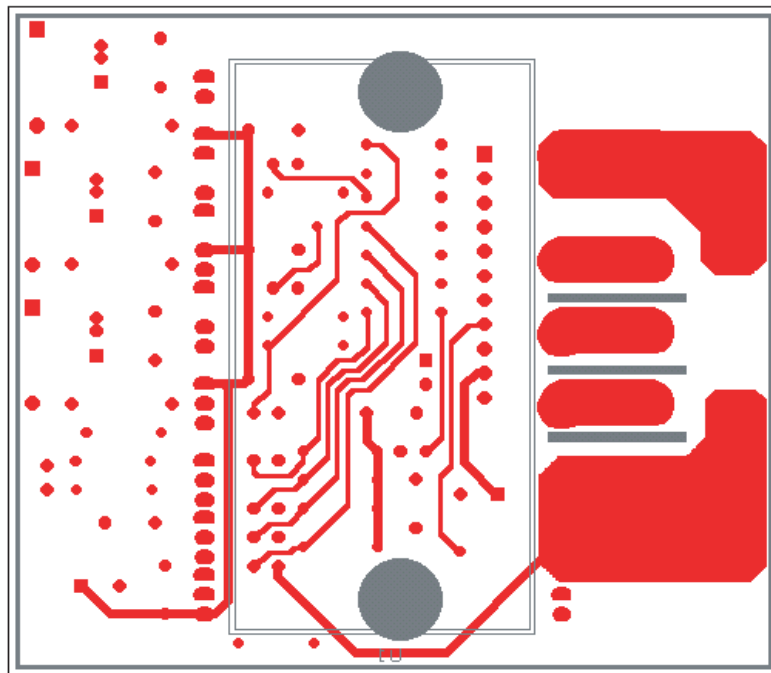

(b) Bottom Side View

3.0 Selection of the Recommended R_{SC} Resistor

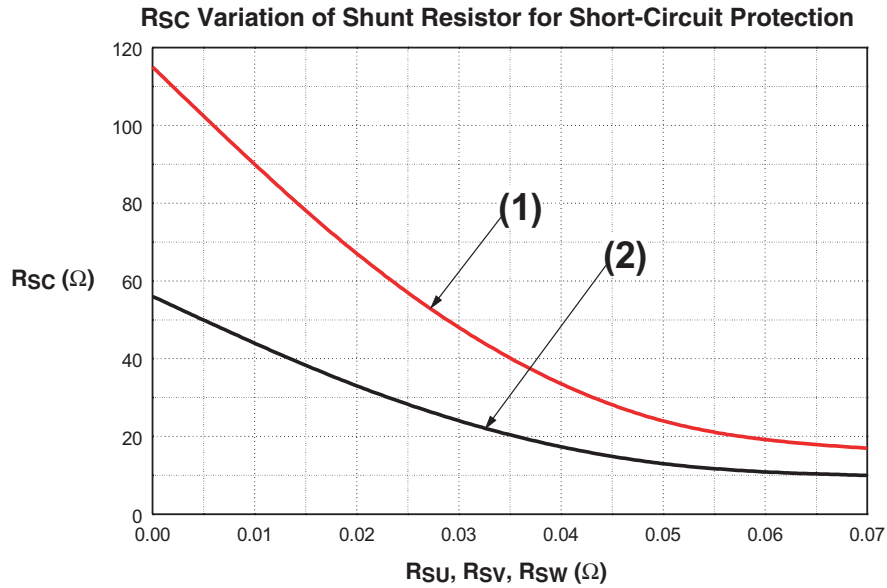

Figure 1. R_{sc} Variation by Change of Shunt Resistors (R_{su}, R_{sv}, R_{sw}) for Short-Circuit Protection

- (1) @ around 100% Rated Current Trip ($I_c = 20A$)
- (2) @ around 150% Rated Current Trip ($I_c = 30A$)

WARNING AND DISCLAIMER

Replace components on the Evaluation Board only with those parts shown on the parts list in the User's Guide. Contact an authorized Fairchild representative with any questions.

The Evaluation board is for demonstration purposes only and neither the Board nor this User's Guide constitute a sales contract or create any kind of warranty, whether express or implied, as to the applications or products involved. Fairchild warranties that its products will meet Fairchild's published specifications but does not guarantee that its products will work in any specific application. Fairchild reserves the right to make changes without notice to any products described herein to improve reliability, function, or design. Either the applicable sales contract signed by Fairchild and Buyer, or if no contract exists Fairchild's Stand Terms and Conditions on the back of Fairchild invoices, govern the terms of sale of the products described herein.

LIFE SUPPORT POLICY

FAIRCHILD'S PRODUCTS ARE NOT AUTHORIZED FOR USE AS CRITICAL COMPONENTS IN LIFE SUPPORT DEVICES OR SYSTEMS WITHOUT THE EXPRESS WRITTEN APPROVAL OF FAIRCHILD SEMICONDUCTOR CORPORATION. As used herein:

1. Life support devices or systems are devices or systems which, (a) are intended for surgical implant into the body, or (b) support or sustain life, or (c) whose failure to perform when properly used in accordance with instructions for use provided in the labeling, can be reasonably expected to result in significant injury to the user.
2. A critical component is any component of a life support device or system whose failure to perform can be reasonably expected to cause the failure of the life support device or system, or to affect its safety or effectiveness.

TRADEMARKS

The following are registered and unregistered trademarks Fairchild Semiconductor owns or is authorized to use and is not intended to be an exhaustive list of all such trademarks.

ACEx™	FAST®	IntelliMAX™	POP™	SPM™
ActiveArray™	FASTr™	ISOPLANAR™	Power247™	Stealth™
Bottomless™	FPS™	LittleFET™	PowerEdge™	SuperFET™
CoolFET™	FRFET™	MICROCOUPLER™	PowerSaver™	SuperSOT™-3
CROSSVOLT™	GlobalOptoisolator™	MicroFET™	PowerTrench®	SuperSOT™-6
DOME™	GTO™	MicroPak™	QFET®	SuperSOT™-8
EcoSPARK™	HiSeC™	MICROWIRE™	QS™	SyncFET™
E ² C MOS™	I ² C™	MSX™	QT Optoelectronics™	TinyLogic®
EnSigna™	i-Lo™	MSXPro™	Quiet Series™	TINYOPTO™
FACT™	ImpliedDisconnect™	OCX™	RapidConfigure™	TruTranslation™
FACT Quiet Series™		OCXPro™	RapidConnect™	UHC™
Across the board. Around the world.™		OPTOLOGIC®	μSerDes™	UltraFET®
The Power Franchise®		OPTOPLANAR™	SILENT SWITCHER®	UniFET™
Programmable Active Droop™		PACMAN™	SMART START™	VCX™